

# THIN BLACK TABLE

Nendo

cappellini

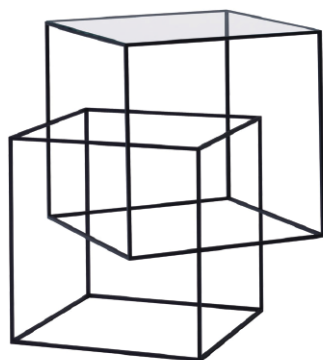

Una creazione lieve e d'effetto: un tavolino basso e geometrico che nasce dall'intersezione di due cubi disassati, il cui profilo superiore ad "L" sostiene un piano d'appoggio in vetro extralight. La struttura in ferro crea un gioco di incastri e trasparenze che ricorda i labirintici disegni di Escher.

## Materiali utilizzati

### Piano:

1. Vetro temperato extralight

### Struttura:

2. Telaio per appoggio piano in lamiera metallica tagliata a laser e piegata, verniciata a polvere epossidica nera con gommino nero per appoggio piano
3. Barra metallica a sezione quadrata, verniciata a polvere epossidica nera

### Piedini:

4. Gomma nera

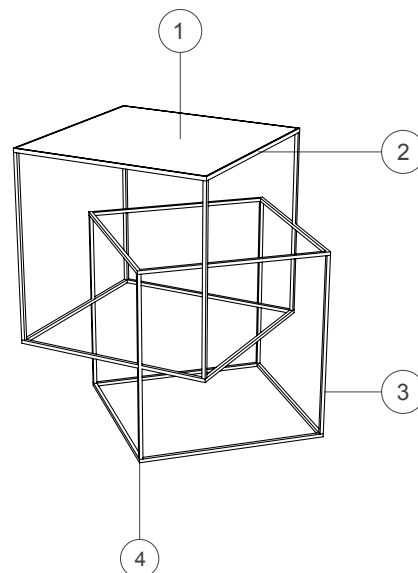

## Dimensioni

### TBT1



51  
20"

47  
18 1/2"

47  
18 1/2"

